



Baureihe 40 - Type 40

2/2 - Wege Magnetventil

2/2 - Way Solenoid valve

Standardtype

Ventil in Ruhestellung geschlossen - (NC). Bei erregtem Magnet baut sich die Druckdifferenz von der Sekundärseite der Membrane über die Servobohrung ab. Die wirksame Druckdifferenz hebt die Membrane vom Ventilsitz ab. Der angegebene Mindestdruck muß als Druckdifferenz für eine einwandfreie Funktion der Servosteuerung immer vorhanden sein.

Standard type

Valve normally closed - NC.

When energised, the pressure decomposes on the secondary side of the diaphragm via the pilot hole. The pressure differential lifts the piston from the seat. The stated minimum pressure is always necessary as pressure differential for accurate operation.



Steuerungsart: Type of control:	servogesteuert pilot operated	Metall. Innenteile: Metallic internals:	Messing und Edelstahl 1.4104 Brass and stainless steel (AISI 430F)
Konstruktion: Construction:	Sitzventil mit Membrandichtung Diaphragm design	Dichtung: Sealing:	NBR NBR
Anschluß: Connection:	G1/4-G2, DIN ISO 228 G1/4-G2, DIN ISO 228	Einbaulage: Installation:	beliebig, Magnet vorzugsweise stehend actuator in any position, preferable upright
Druck: Pressure:	0,3-20 bar (s. Tabelle) 0,3-20 bar (see table)	Anschlußspannung: Supply voltage:	AC: 24,42,110,230V 50Hz DC: 24,110,196V=
Durchflußmedium: Medium:	neutrale, gasförmige u. flüssige Medien neutral, gaseous and liquid medium	Spannungstoleranz: Voltage tolerance:	+5% / -10% +5% / -10%
Viskosität: Viscosity:	22mm ² /s 22mm ² /s	Leistungsaufnahme: Power-consumption:	1182 = 6,8 Watt 0182 = 14,5/10,5 VA 1032 = 11 Watt 0032 = 24/15 VA 1012 = 18,5 Watt 0012 = 35/24 VA 1148 = 10 Watt 0148 = 9 VA
Mediumtemperatur: Medium temperature:	-10 bis +80°C -10 up to +80°C	Schutzart: Protection class:	IP65 nach DIN 40050 IP65 according to DIN 40050
Umgebungstemperatur: Ambient temperature:	+35°C +35°C	Einschaltdauer: Duty factor:	100% ED-VDE 0580 100% ED-VDE 0580
Ventilgehäuse: Body material:	../10../.. = Messing / Brass ../08../.. = Edelst.1.4581 / St. steel (AISI 316Ti)	Kabelanschluß: Cable connection:	Gerätestecker DIN 43650 DIN 43650 - plug

DN	Sitz Orifice Ømm	Kv-Wert Flow-rate m ³ /h	Standardtype Standard type	max. Druck bei Magnettype / max. pressure reg. solen. type Ex-Schutz Ex II 2G Eex m II T4			
				.182	.032	.012-NO	.148
1/4	13,5	1,6	D4021/1001/....	0,3-20	0,3-20	0,3-20	0,3-20
3/8	13,5	3,3	D4022/1001/....	0,3-20	0,3-20	0,3-20	0,3-20
1/2	13,5	3,8	D4023/1001/....	0,3-20	0,3-20	0,3-20	0,3-20
3/4	27,5	11,0	D4024/1001/....	0,3-16	0,3-20	0,3-20	0,3-20
1	27,5	13,0	D4025/1001/....	0,3-16	0,3-20	0,3-20	0,3-20
5/4	40	30,0	B4026/1001/....	-	0,5-16	0,5-16	0,5-16
6/4	40	32,0	B4027/1001/....	-	0,5-16	0,5-16	0,5-16
2	50	36,0	B4028/1001/....	-	0,5-16	0,5-16	0,5-16
Edelstahl 1.4581 / Stainless steel 1.4581 (AISI 316 Ti)							
1/4	13	1,6	D4021/0801/....	-	0,3-20	0,3-20	0,3-20
3/8	13	3,3	D4022/0801/....	-	0,3-20	0,3-20	0,3-20
1/2	13	3,8	D4023/0801/....	-	0,3-20	0,3-20	0,3-20
3/4	25	11,0	D4024/0801/....	-	0,3-20	0,3-20	0,3-20
1	25	13,0	D4025/0801/....	-	0,3-20	0,3-20	0,3-20
5/4	40	30,0	B4026/0801/....	-	0,5-16	0,5-16	0,5-16
6/4	40	32,0	B4027/0801/....	-	0,5-16	0,5-16	0,5-16
2	50	36,0	B4028/0801/....	-	0,5-16	0,5-16	0,5-16

Maßzeichnung Standardausführung
Dimensional drawing of standard type

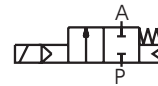
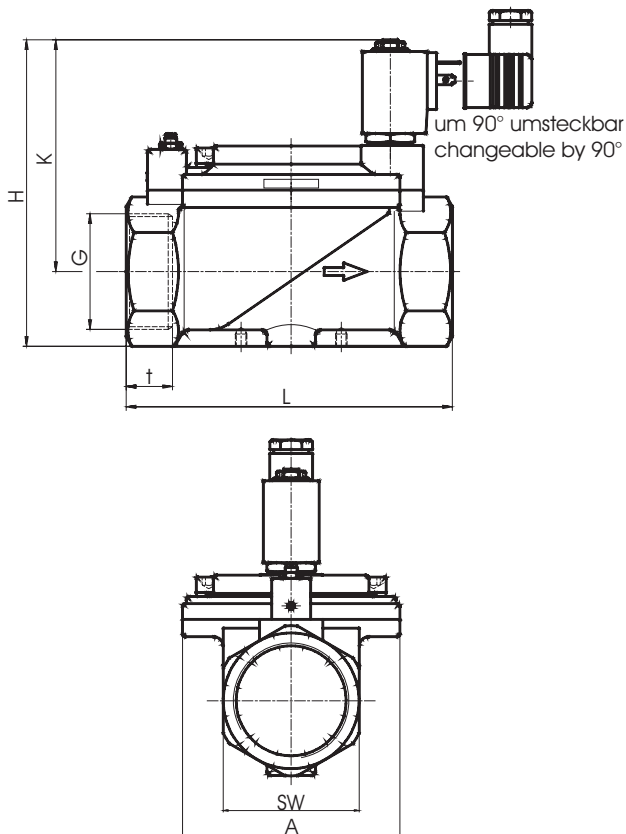

Schaltfunktion/Function:
in Ruhestellung gesperrt - NC.
normally closed - NC.

Anschlußplan / Connection diagram

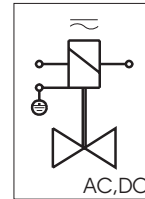

Für Wechsel- und Gleichspannung.
For AC and DC.

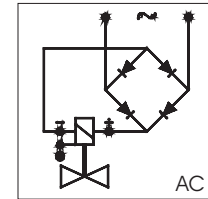

Mit vorgeschaltetem Gleichrichter für Wechselspannung.
With rectifier for AC connection.

Erdung oder Schutzschaltung nach Vorschrift des zuständigen EVU.
Grounding or earthing of the protective circuit in accordance with regulations of the responsible electric supply company.

Absicherung entsprechend der Stromaufnahme vorsehen.
Appropriate protection according to the power-consumption.

Magnet Solenoid	.182		.032 / .148 / .012			
Type	4021-4023	4024-4025	4021-4023	4024-4025	4026-4027	4028
G	1/4-1/2	3/4-1	1/4-1/2	3/4-1	5/4-6/4	2
A	V.45x45	V.70x70	V.45x45	V.70x70	V.96x96	V.112x112
H	95	106	105	121	143	161
K	75	82	90	97	110	121
L	67	96	67	96	140	168
SW	27	41	27	41	58	70
t	12	16	12	16	22	25
Pg	11	11	11	11	11	11
kg	0,8	1,2	0,8	1,2	2,8	3,9

Ventiloptionen

Stromlos geöffnet = NO
Non energised open = NO

Dichtung = FKM, EPDM
Seal = FKM, EPDM

Andere Durchflußmedien und Viskositäten
Varying medium and viscosity ranges

Abweichende Temperaturen und Drücke
Varying temperature and pressure ranges

Stellungsanzeiger (Endschalter ab G3/4) = EH
Position indicator (Reed contact from G3/4) = EH

Ex-Schutz = Ex II 2G EEx md IIC T4, T5 oder T6
Explosion proof = Ex II 2G EEx md IIC T4, T5 or T6

/

Valve options

Handbetätigung = HA
Manual operation = HA

Regulierbare Schließdämpfung (ab G3/4) = SR
Device for adjustable close damping (from G3/4) = SR

Öl- und fettfrei = OF
Free of oil and grease = OF (for oxygen applications)

Buntmetallfrei = BF
Free of non-ferrous metal = BF

Temperaturausführung bis +130°C = TM
Design for high temperature up to +130°C = TM

Abgedichteter Ankerraum = AA
Sealed plunger = AA

Stückliste - Parts list

- K1.1 Armatur / Valve body
- K2.1 Deckel / Bonnet
- *K3.1 Membrane / Diaphragm
- *K3.4 Feder / Spring
- K3.10 Verschlussstopfen / Sealing plug
- *K3.12 O-Ring / O-ring
- K3.13 Dämpfungsschraube / Damping screw
- K3.15 Filteraufnahme / Filter retainer
- K3.21 Zylinderschraube / Cylinder screw
- K3.22 Federring / Lock washer
- *K3.23 O-Ring / O-ring
- *K3.24 O-Ring / O-ring
- K3.25 Filtersieb / Strainer
- K3.28 6-kt. Mutter / Hexagon nut
- K5.1 Magnethülse / Solenoid tube
- K5.2 Magnetanker / Solenoid plunger
- K5.3 Feder / Spring
- K5.4 Mutter / Nut
- K5.5 Wellscheibe / Corrugated disk
- K5.6 Dichtung / Seal
- K5.7 O-Ring / O-ring
- K6.1 Magnet / Solenoid
- K7.1 Gerätestecker / Plug

* = Bestandteil des Ersatzteilpäckchens
(je nach Ausführung freibleibend)
* = Part of the service-set.
(The specifications are without obligation)

Baureihe / Type D4021 - D4025
Edelstahl und Messingausführung
Stainless steel and brass design

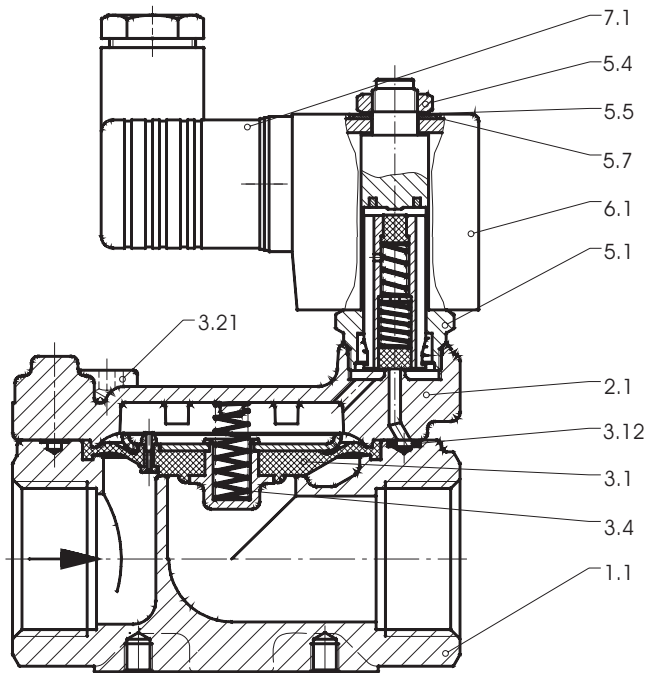

Regulierbare Schließdämpfung - SR (von G5/4-G2 serienmäßig)
Device for adjustable close damping - SR
(From G5/4-G2 standard)

Baureihe / Type B4026 - B4028

Schraube nach rechts drehen : Ventil schließt langsamer
Screw to the right site : Valve closes slower
Schraube nach links drehen : Ventil schließt schneller
Screw to the left site : Valve closes - faster

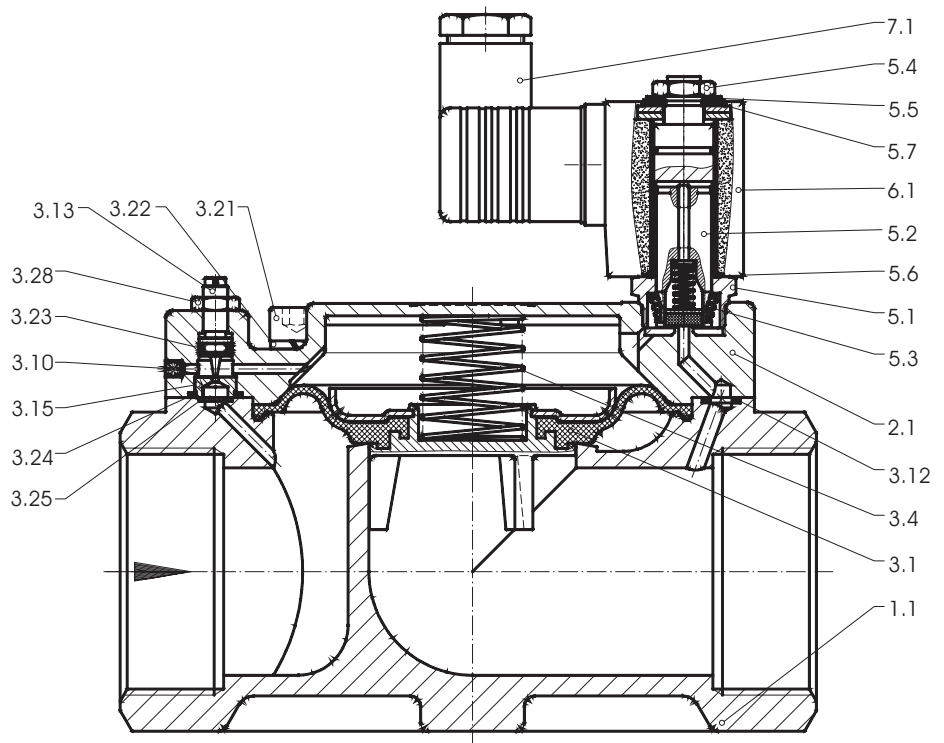
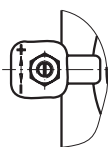
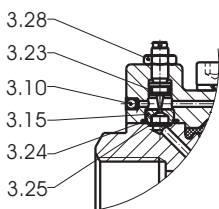

Ventiloptionen / Optional extras

Handbetätigung - HA
Manual operation - HA

- K3.62 Spindel / Spindle
- K3.65 O-Ring / O-ring
- K2.1 Deckel / Bonnet
- K5.1 Magnethülse / Solenoid tube

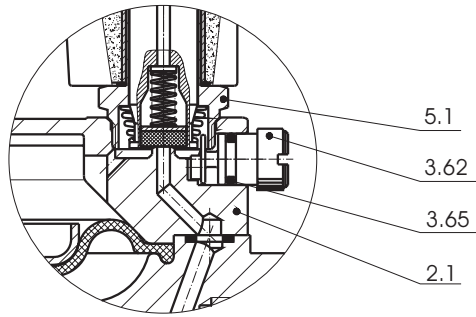

Stellungsanzeiger - EH (ab G3/4)
Position indicator - EH (from G3/4)

- K3.75 Zwischenverschraubung / Screw joint
- K3.76 Spindel / Spindle
- K3.79 O-Ring / O-ring
- K3.82 Senkschraube / Countersunk bolt
- K3.83 Permanentmagnet / Permanent magnet
- K3.84 Klemmring / Clamping ring
- K3.85 Verschraubung / Screw joint
- K3.86 Endschalter / Position indicator

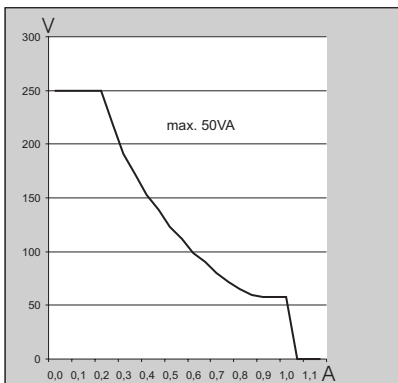
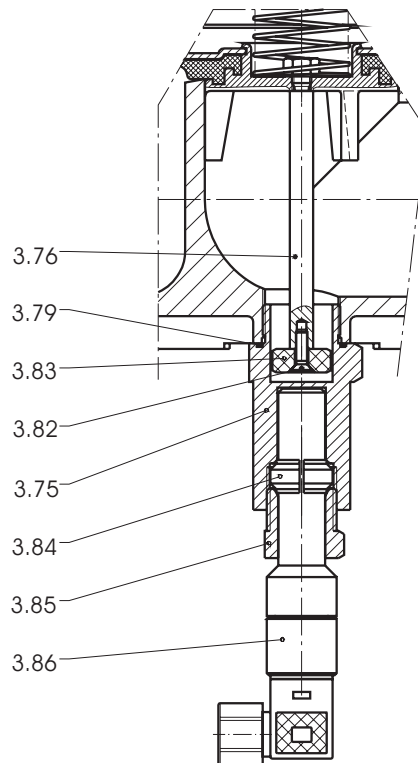

Schaltleistungsdiagramm
Braking capacity diagram

Anschlußplan
Connection diagram
Endschalter / Position indicator

